



reventon
INDUSTRIAL SOLUTIONS

Technical documentation

AIR WATER HEATERS IN EPP CASING HC-3S SERIES

MODELS:

REVENTON GROUP HC 20-3S
REVENTON GROUP HC 30-3S
REVENTON GROUP HC 35-3S
REVENTON GROUP HC 45-3S
REVENTON GROUP HC 50-3S
REVENTON GROUP HC 70-3S



Table of contents

- 1. INTRODUCTION
 - 1.1 PRECAUTIONS
 - 1.2 TRANSPORT
 - 1.3 PACKAGE CONTENT
 - 1.4 USE
- 2. DEVICE CHARACTERISTICS
 - 2.1. CONSTRUCTION AND PRINCIPLE OF OPERATION
 - 2.2. DEVICE DIMENSIONS
 - 2.3. DEVICE TECHNICAL DATA
- 3. ASSEMBLY
 - 3.1. GENERAL PRINCIPLES
 - 3.2. ROTATING MOUNTING BRACKET
- 4. INSTALLATION INSTRUCTIONS
 - 4.1. CONNECTION OF THE DEVICE TO THE HYDAULIC SYSTEM
 - 4.2. CONNECTION OF THE DEIVCE TO THE ELECTRICAL SYSTEM
- 5. PRECAUTIONS & WARNINGS
- 6. CONTROLS
- 7. CONNECTION SCHEMES
- 8. TERMS OF WARRANTY

1. INTRODUCTION

Thank you very much for purchasing Reventon Group device. We would like to congratulate you on excellent choice. Please read and keep this manual.

1.1 PRECAUTIONS

The buyer and the user of the air water heater Reventon Group brand should read carefully the following instructions and proceed to the content recommendations. Proceeding due to the following instruction guarantees the correct usage and safety. In case of any doubts please contact directly the producer Reventon Group sp. z o.o. The producer reserves the rights to make changes to the technical documentation without previous notice. Reventon Group sp. z o.o. is not responsible for the damages which occur due to improper installation, not keeping the device in repair or using the device out of line. The installation should be carried out by the professional installers, who possess the qualifications to install these types of devices. The installers are responsible for making the installation as instructed in the technical data. In case of unserviceable please plug out the device and contact with the authorized for repair person or the supplier. During the installation, use, service and periodical inspections all regulations and safety rules must be followed.

1.2 TRANSPORT

During the acceptance of goods, it is needed to check the device to exclude any damages. During the transport, it is needed to use the proper equipment, it is necessary to carry the device by two people. In case of any damages please fill in the damage report in presence of the supplier.

1.3 PACKAGE CONTENT

- heater
- operation and maintenance manual and warranty card

1.4 USE

Heating devices Reventon Group HC series are used to heat spaces such as: production halls, warehouses, commercial room, service spaces, garages, workshops, greenhouses, tents, shops, malls, shopping malls etc. However, heating devices should not be used in corrosive environments for aluminum, copper and steel as well as in highly dusty environments (above 0.3 g /m³). The devices should not be installed in rooms where they would be exposed to high humidity or direct contact with water.

2. DEVICE CHARACTERISTICS

2.1 CONSTRUCTION AND PRINCIPLE OF OPERATION

Casing: made of expanded polypropylene (EPP). This material is characterized by low density (light weighted) and high chemical and physical resistance. It has an excellent sound and thermal insulation properties. Moreover, material is environmentally friendly and "green", i.e. 100% recyclable.

Air stators: made of polypropylene PP. It is possible to adjust manually the air stators to achieve the needed direction of the air flow. There are also versions with confuser (increased airflow range) or with diffuser 360° (better mixing of supplied and room air).

Heating coil: made of copper and aluminum. Supplied by distribution medium (heating or cooling), which circulates through the coil and releases or extracts heat from the air. The coil has the following technical parameters: the maximum temperature of the heating factor is 120°C; maximum pressure 1,6 MPa; headers diameter ¾". Depending on dimensions of the device the heaters are equipped with 1, 2 or 3-row heating coils.

Axial blowing fan: made of galvanized steel. The objective of the fan is to ensure air flow through the exchanger. It has a single-phase, three speed motor with the following parameters: protection degree IP54, rate current 0,54A-1,08A (depending on model and operating mode). Models HC20-3S, HC30-3S, HC35-3S, HC45-3S have fans with diameter 400 mm. Models HC50-3S and HC70-3S have fans with diameter 450 mm.

Rotating mounting bracket (optional equipment): enables the device to be installed in several configurations (depending on the requirements) and the unit to be rotated in a horizontal plane.

2.2 DEVICE DIMENSIONS

- HC 20-3S, HC 30-3S, HC 35-3S and HC 45-3S:

- height (A): 598 mm
- width (B): 636 mm
- depth (C): 340 mm

- HC 50-3S and HC 70-3S:

- height (A): 698 mm
- width (B): 739 mm
- depth (C): 360 mm

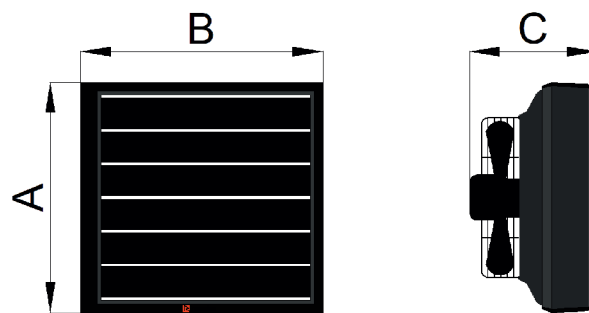

2.3 DEVICE TECHNICAL DATA

TECHNICAL DATA		HC 20-3S	HC 30-3S	HC 35-3S	HC 45-3S	HC 50-3S	HC 70-3S
Product code		WHHC20-3S-1759	WHHC30-3S-1760	WHHC35-3S-1761	WHHC45-3S-1762	WHHC50-3S-1763	WHHC70-3S-1764
Nominal heating capacity [kW] *	III STAGE	21,4	26,4	30,3	42,0	44,3	60,6
	II STAGE	17,3	20,3	22,9	28,9	32,5	40,1
	I STAGE	13,3	15,5	17,3	21,1	26,5	32,7
Heating capacity range [kW] **		1,55 – 28,4	1,8 – 34,9	2,14 – 40,1	3,21 – 55,6	3,87 – 58,5	5,0 – 80,1
Maximum airflow [m ³ /h]	III STAGE	3200	3100	2700	2500	4000	3400
	II STAGE	2150	1950	1700	1450	2400	1900
	I STAGE	1350	1250	1100	950	1750	1450
Maximum horizontal range [m]		19	18	15	14	21	18
Number of rows [pcs.]		1	1	2	2	2	3
Capacity of water [dm ³]		0,65	0,8	1,35	1,7	1,95	2,85
Maximum temperature of working fluid [°C]		120	120	120	120	120	120
Maximum working pressure [Mpa]		1,6	1,6	1,6	1,6	1,6	1,6
Connection diameter ["]		3/4	3/4	3/4	3/4	3/4	3/4
Power supply [V] / Frequency [Hz]		230/50	230/50	230/50	230/50	230/50	230/50
Rated motor current [A]	III STAGE	0,84	0,84	0,84	0,84	1,08	1,08
	II STAGE	0,65	0,65	0,65	0,65	0,86	0,86
	I STAGE	0,54	0,54	0,54	0,54	0,70	0,70
Motor speed [rpm]	III STAGE	1400	1400	1400	1400	1360	1360
	II STAGE	1050	1050	1050	1050	1050	1050
	I STAGE	750	750	750	750	750	750
Motor power [W]	III STAGE	190	190	190	190	240	240
	II STAGE	150	150	150	150	190	190
	I STAGE	120	120	120	120	160	160
Protection degree IP [-]		54	54	54	54	54	54
Net weight [kg]		11,5	12	12,5	14	17,5	19,5
Noise [dB]***	III STAGE	55	55	54	54	59	58
	II STAGE	49	49	48	48	54	53
	I STAGE	47	47	46	46	50	49

* for parameters 90/70°C and 0°C inlet

** max. 120/90°C, 0°C inlet, III stage // min. 40/30°C, 20°C inlet, I stage

*** measurement at the distance 5 m

Parameters	HC 20-3S-3 stage 3200 m3/h				
Supply/return water temperature [°C]	120/90				
Dry bulb air inlet temperature [°C]	0	5	10	15	20
Heating capacity [kW]	28,4	26,6	24,8	23,1	21,4
Dry bulb air outlet temperature [°C]	24,7	28,5	32,4	36,2	40
Water flow [m³/h]	0,84	0,78	0,73	0,68	0,63
Pressure drop in the heat exchanger [kPa]	4	4	5	4	4

Parameters	HC 20-3S-3 stage 3200 m3/h				
Supply/return water temperature [°C]	90/70				
Dry bulb air inlet temperature [°C]	0	5	10	15	20
Heating capacity [kW]	21,4	19,7	18	16,4	14,7
Dry bulb air outlet temperature [°C]	18,6	22,4	26,2	30	33,8
Water flow [m³/h]	0,94	0,87	0,79	0,72	0,65
Pressure drop in the heat exchanger [kPa]	6	5	4	5	4

Parameters	HC 20-3S-3 stage 3200 m3/h				
Supply/return water temperature [°C]	80/60				
Dry bulb air inlet temperature [°C]	0	5	10	15	20
Heating capacity [kW]	18,1	16,4	14,7	13,1	11,5
Dry bulb air outlet temperature [°C]	15,7	19,5	23,3	27	30,8
Water flow [m³/h]	0,79	0,72	0,65	0,58	0,51
Pressure drop in the heat exchanger [kPa]	4	5	4	3	3

Parameters	HC 20-3S-3 stage 3200 m3/h				
Supply/return water temperature [°C]	70/50				
Dry bulb air inlet temperature [°C]	0	5	10	15	20
Heating capacity [kW]	14,7	13,1	11,5	9,90	8,37
Dry bulb air outlet temperature [°C]	12,8	16,6	20,3	24,1	27,8
Water flow [m³/h]	0,64	0,57	0,50	0,43	0,37
Pressure drop in the heat exchanger [kPa]	4	3	3	4	3

Parameters	HC 20-3S-3 stage 3200 m3/h				
Supply/return water temperature [°C]	50/30				
Dry bulb air inlet temperature [°C]	0	5	10	15	20
Heating capacity [kW]	7,95	6,44	4,98	3,55	2,18
Dry bulb air outlet temperature [°C]	6,9	10,7	14,5	18,3	22,0
Water flow [m³/h]	0,35	0,28	0,22	0,15	0,09
Pressure drop in the heat exchanger [kPa]	3	2	4	4	1

Parameters	HC 20-3S-3 stage 3200 m3/h				
Supply/return water temperature [°C]	40/30				
Dry bulb air inlet temperature [°C]	0	5	10	15	20
Heating capacity [kW]	8,31	6,76	5,25	3,78	2,36
Dry bulb air outlet temperature [°C]	7,2	11	14,7	18,5	22,2
Water flow [m³/h]	0,72	0,59	0,45	0,33	0,20
Pressure drop in the heat exchanger [kPa]	5	4	5	3	4

Parameters	HC 30-3S-3 stage 3100 m3/h				
Supply/return water temperature [°C]	120/90				
Dry bulb air inlet temperature [°C]	0	5	10	15	20
Heating capacity [kW]	34,9	32,7	30,6	28,4	26,3
Dry bulb air outlet temperature [°C]	31,4	34,9	38,4	41,9	45,4
Water flow [m³/h]	1,03	0,97	0,9	0,84	0,78
Pressure drop in the heat exchanger [kPa]	6	6	5	4	4

Parameters	HC 30-3S-3 stage 3100 m3/h				
Supply/return water temperature [°C]	90/70				
Dry bulb air inlet temperature [°C]	0	5	10	15	20
Heating capacity [kW]	26,4	24,2	22,1	20,1	18,1
Dry bulb air outlet temperature [°C]	23,7	27,1	30,6	34	37,4
Water flow [m³/h]	1,16	1,07	0,98	0,89	0,8
Pressure drop in the heat exchanger [kPa]	7	7	6	5	4

Parameters	HC 30-3S-3 stage 3100 m3/h				
Supply/return water temperature [°C]	80/60				
Dry bulb air inlet temperature [°C]	0	5	10	15	20
Heating capacity [kW]	22,2	20,1	18,1	16,1	14,2
Dry bulb air outlet temperature [°C]	19,9	23,4	26,8	30,2	33,6
Water flow [m³/h]	0,97	0,88	0,79	0,71	0,62
Pressure drop in the heat exchanger [kPa]	6	5	4	5	4

Parameters	HC 30-3S-3 stage 3100 m3/h				
Supply/return water temperature [°C]	70/50				
Dry bulb air inlet temperature [°C]	0	5	10	15	20
Heating capacity [kW]	18	16	14	12,1	10,2
Dry bulb air outlet temperature [°C]	16,2	19,6	23,1	26,5	29,8
Water flow [m³/h]	0,79	0,7	0,61	0,53	0,45
Pressure drop in the heat exchanger [kPa]	4	5	4	3	4

Parameters	HC 30-3S-3 stage 3100 m3/h				
Supply/return water temperature [°C]	50/30				
Dry bulb air inlet temperature [°C]	0	5	10	15	20
Heating capacity [kW]	9,68	7,82	6,0	4,25	2,58
Dry bulb air outlet temperature [°C]	8,7	12,1	15,6	19,0	22,5
Water flow [m³/h]	0,42	0,34	0,26	0,18	0,11
Pressure drop in the heat exchanger [kPa]	4	3	2	5	2

Parameters	HC 30-3S-3 stage 3100 m3/h				
Supply/return water temperature [°C]	40/30				
Dry bulb air inlet temperature [°C]	0	5	10	15	20
Heating capacity [kW]	10,2	8,27	6,4	4,58	2,84
Dry bulb air outlet temperature [°C]	9,1	12,6	16,0	19,3	22,7
Water flow [m³/h]	0,88	0,72	0,55	0,4	0,25
Pressure drop in the heat exchanger [kPa]	5	5	3	4	5

Parameters	HC 35-3S-3 stage 2700 m3/h				
Supply/return water temperature [°C]	120/90				
Dry bulb air inlet temperature [°C]	0	5	10	15	20
Heating capacity [kW]	40,1	37,6	35,1	32,7	30,3
Dry bulb air outlet temperature [°C]	41,3	44,4	47,5	50,5	53,5
Water flow [m³/h]	1,18	1,11	1,04	0,97	0,89
Pressure drop in the heat exchanger [kPa]	3	4	4	3	3

Parameters	HC 35-3S-3 stage 2700 m3/h				
Supply/return water temperature [°C]	90/70				
Dry bulb air inlet temperature [°C]	0	5	10	15	20
Heating capacity [kW]	30,3	27,9	25,5	23,2	20,9
Dry bulb air outlet temperature [°C]	31,2	34,2	37,2	40,2	43,1
Water flow [m³/h]	1,33	1,23	1,12	1,02	0,92
Pressure drop in the heat exchanger [kPa]	4	3	4	4	3

Parameters	HC 35-3S-3 stage 2700 m3/h				
Supply/return water temperature [°C]	80/60				
Dry bulb air inlet temperature [°C]	0	5	10	15	20
Heating capacity [kW]	25,6	23,3	21	18,7	16,5
Dry bulb air outlet temperature [°C]	26,4	29,4	32,4	35,3	38,2
Water flow [m³/h]	1,13	1,02	0,92	0,82	0,72
Pressure drop in the heat exchanger [kPa]	4	4	3	2	4

Parameters	HC 35-3S-3 stage 2700 m3/h				
Supply/return water temperature [°C]	70/50				
Dry bulb air inlet temperature [°C]	0	5	10	15	20
Heating capacity [kW]	21,0	18,7	16,4	14,2	12,1
Dry bulb air outlet temperature [°C]	21,6	24,6	27,6	30,5	33,4
Water flow [m³/h]	0,92	0,82	0,72	0,62	0,53
Pressure drop in the heat exchanger [kPa]	3	2	4	3	2

Parameters	HC 35-3S-3 stage 2700 m3/h				
Supply/return water temperature [°C]	50/30				
Dry bulb air inlet temperature [°C]	0	5	10	15	20
Heating capacity [kW]	11,6	9,48	7,4	5,36	3,38
Dry bulb air outlet temperature [°C]	12,0	14,9	17,9	20,8	23,7
Water flow [m³/h]	0,50	0,41	0,32	0,23	0,15
Pressure drop in the heat exchanger [kPa]	2	3	2	4	3

Parameters	HC 35-3S-3 stage 2700 m3/h				
Supply/return water temperature [°C]	40/30				
Dry bulb air inlet temperature [°C]	0	5	10	15	20
Heating capacity [kW]	11,9	9,71	7,59	5,52	3,51
Dry bulb air outlet temperature [°C]	12,2	15,2	18,1	21,0	23,9
Water flow [m³/h]	1,03	0,84	0,66	0,48	0,30
Pressure drop in the heat exchanger [kPa]	4	3	3	2	2

Parameters	HC 45-3S-3 stage 2500 m ³ /h				
Supply/return water temperature [°C]	120/90				
Dry bulb air inlet temperature [°C]	0	5	10	15	20
Heating capacity [kW]	55,6	52,1	48,8	45,6	42,4
Dry bulb air outlet temperature [°C]	61,8	64,1	66,3	68,5	70,7
Water flow [m ³ /h]	1,64	1,54	1,44	1,35	1,25
Pressure drop in the heat exchanger [kPa]	16	16	15	13	11

Parameters	HC 45-3S-3 stage 2500 m ³ /h				
Supply/return water temperature [°C]	90/70				
Dry bulb air inlet temperature [°C]	0	5	10	15	20
Heating capacity [kW]	42,0	38,8	35,6	32,5	29,5
Dry bulb air outlet temperature [°C]	46,7	48,9	51,1	53,2	55,2
Water flow [m ³ /h]	1,85	1,71	1,57	1,43	1,3
Pressure drop in the heat exchanger [kPa]	21	18	16	15	12

Parameters	HC 45-3S-3 stage 2500 m ³ /h				
Supply/return water temperature [°C]	80/60				
Dry bulb air inlet temperature [°C]	0	5	10	15	20
Heating capacity [kW]	36,2	33,0	29,9	26,9	24,0
Dry bulb air outlet temperature [°C]	40,3	42,4	44,5	46,6	48,6
Water flow [m ³ /h]	1,59	1,45	1,31	1,18	1,05
Pressure drop in the heat exchanger [kPa]	17	16	13	11	10

Parameters	HC 45-3S-3 stage 2500 m ³ /h				
Supply/return water temperature [°C]	70/50				
Dry bulb air inlet temperature [°C]	0	5	10	15	20
Heating capacity [kW]	30,3	27,2	24,2	21,2	18,3
Dry bulb air outlet temperature [°C]	33,7	35,8	37,9	39,9	41,9
Water flow [m ³ /h]	1,33	1,19	1,06	0,93	0,8
Pressure drop in the heat exchanger [kPa]	14	11	10	8	6

Parameters	HC 45-3S-3 stage 2500 m ³ /h				
Supply/return water temperature [°C]	50/30				
Dry bulb air inlet temperature [°C]	0	5	10	15	20
Heating capacity [kW]	18,4	15,4	12,5	9,65	6,78
Dry bulb air outlet temperature [°C]	20,4	22,5	24,4	26,3	28,1
Water flow [m ³ /h]	0,8	0,67	0,54	0,42	0,29
Pressure drop in the heat exchanger [kPa]	7	6	4	5	2

Parameters	HC 45-3S-3 stage 2500 m ³ /h				
Supply/return water temperature [°C]	40/30				
Dry bulb air inlet temperature [°C]	0	5	10	15	20
Heating capacity [kW]	17,4	14,4	11,6	8,78	6,02
Dry bulb air outlet temperature [°C]	19,3	21,3	23,4	25,3	27,2
Water flow [m ³ /h]	1,5	1,25	1,0	0,76	0,52
Pressure drop in the heat exchanger [kPa]	18	13	10	8	4

Parameters	HC 50-3S-3 stage 4000 m ³ /h				
Supply/return water temperature [°C]	120/90				
Dry bulb air inlet temperature [°C]	0	5	10	15	20
Heating capacity [kW]	58,5	54,9	51,5	48,1	44,7
Dry bulb air outlet temperature [°C]	40,7	43,9	47,1	50,3	53,4
Water flow [m ³ /h]	1,73	1,62	1,52	1,42	1,32
Pressure drop in the heat exchanger [kPa]	7	7	8	7	6

Parameters	HC 50-3S-3 stage 4000 m ³ /h				
Supply/return water temperature [°C]	90/70				
Dry bulb air inlet temperature [°C]	0	5	10	15	20
Heating capacity [kW]	44,3	40,9	37,6	34,3	31,1
Dry bulb air outlet temperature [°C]	30,8	33,9	37,1	40,2	43,2
Water flow [m ³ /h]	1,95	1,80	1,66	1,51	1,37
Pressure drop in the heat exchanger [kPa]	10	8	7	8	7

Parameters	HC 50-3S-3 stage 4000 m ³ /h				
Supply/return water temperature [°C]	80/60				
Dry bulb air inlet temperature [°C]	0	5	10	15	20
Heating capacity [kW]	38,0	34,7	31,5	28,3	25,2
Dry bulb air outlet temperature [°C]	26,5	29,6	32,7	35,7	38,8
Water flow [m ³ /h]	1,67	1,52	1,38	1,24	1,11
Pressure drop in the heat exchanger [kPa]	8	8	7	6	6

Parameters	HC 50-3S-3 stage 4000 m ³ /h				
Supply/return water temperature [°C]	70/50				
Dry bulb air inlet temperature [°C]	0	5	10	15	20
Heating capacity [kW]	31,8	28,5	25,3	22,2	19,1
Dry bulb air outlet temperature [°C]	22,1	25,2	28,3	31,3	34,3
Water flow [m ³ /h]	1,39	1,25	1,11	0,97	0,84
Pressure drop in the heat exchanger [kPa]	7	6	6	5	4

Parameters	HC 50-3S-3 stage 4000 m ³ /h				
Supply/return water temperature [°C]	50/30				
Dry bulb air inlet temperature [°C]	0	5	10	15	20
Heating capacity [kW]	19,1	16,0	12,9	9,92	6,92
Dry bulb air outlet temperature [°C]	13,3	16,3	19,3	22,3	25,2
Water flow [m ³ /h]	0,83	0,69	0,56	0,43	0,30
Pressure drop in the heat exchanger [kPa]	4	4	3	4	2

Parameters	HC 50-3S-3 stage 4000 m ³ /h				
Supply/return water temperature [°C]	40/30				
Dry bulb air inlet temperature [°C]	0	5	10	15	20
Heating capacity [kW]	18,2	15,1	12,1	9,15	6,23
Dry bulb air outlet temperature [°C]	12,7	15,7	18,7	21,7	24,6
Water flow [m ³ /h]	1,58	1,31	1,05	0,79	0,54
Pressure drop in the heat exchanger [kPa]	8	7	6	4	3

Parameters	HC 70-3S-3 stage 3400 m ³ /h				
Supply/return water temperature [°C]	120/90				
Dry bulb air inlet temperature [°C]	0	5	10	15	20
Heating capacity [kW]	80,1	75,2	70,5	65,8	61,2
Dry bulb air outlet temperature [°C]	65,6	67,7	69,8	71,8	73,7
Water flow [m ³ /h]	2,37	2,22	2,08	1,94	1,81
Pressure drop in the heat exchanger [kPa]	7	7	6	5	5

Parameters	HC 70-3S-3 stage 3400 m ³ /h				
Supply/return water temperature [°C]	90/70				
Dry bulb air inlet temperature [°C]	0	5	10	15	20
Heating capacity [kW]	60,6	55,9	51,4	46,9	42,6
Dry bulb air outlet temperature [°C]	49,6	51,6	53,6	55,5	57,4
Water flow [m ³ /h]	2,67	2,46	2,26	2,07	1,88
Pressure drop in the heat exchanger [kPa]	8	8	7	6	5

Parameters	HC 70-3S-3 stage 3400 m ³ /h				
Supply/return water temperature [°C]	80/60				
Dry bulb air inlet temperature [°C]	0	5	10	15	20
Heating capacity [kW]	52,2	47,6	43,2	38,8	34,6
Dry bulb air outlet temperature [°C]	42,7	44,7	46,7	48,5	50,4
Water flow [m ³ /h]	2,29	2,09	1,90	1,71	1,52
Pressure drop in the heat exchanger [kPa]	7	6	5	4	5

Parameters	HC 70-3S-3 stage 3400 m ³ /h				
Supply/return water temperature [°C]	70/50				
Dry bulb air inlet temperature [°C]	0	5	10	15	20
Heating capacity [kW]	43,8	39,3	35,0	30,7	26,6
Dry bulb air outlet temperature [°C]	35,8	37,8	39,7	41,5	43,3
Water flow [m ³ /h]	1,92	1,72	1,53	1,34	1,16
Pressure drop in the heat exchanger [kPa]	5	5	5	4	3

Parameters	HC 70-3S-3 stage 3400 m ³ /h				
Supply/return water temperature [°C]	50/30				
Dry bulb air inlet temperature [°C]	0	5	10	15	20
Heating capacity [kW]	26,7	22,4	18,3	14,1	9,94
Dry bulb air outlet temperature [°C]	21,9	23,7	25,5	27,1	28,7
Water flow [m ³ /h]	1,16	0,97	0,79	0,61	0,43
Pressure drop in the heat exchanger [kPa]	3	4	3	3	4

Parameters	HC 70-3S-3 stage 3400 m ³ /h				
Supply/return water temperature [°C]	40/30				
Dry bulb air inlet temperature [°C]	0	5	10	15	20
Heating capacity [kW]	25,1	20,9	16,8	12,7	8,78
Dry bulb air outlet temperature [°C]	20,5	22,4	24,2	26,0	27,7
Water flow [m ³ /h]	2,17	1,81	1,45	1,1	0,76
Pressure drop in the heat exchanger [kPa]	7	5	5	5	4

3. ASSEMBLY

3.1. GENERAL PRINCIPLES

During installation, ensure a free air flow to the device and do not restrict the air stream supply. The figures below show the recommended distances between the heater and building partitions:

a) in case of wall mounting

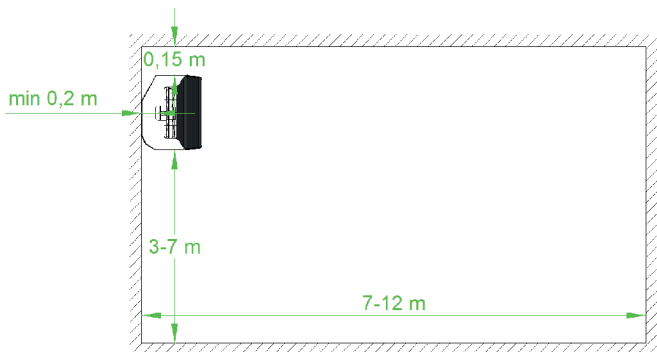

b) in case of ceiling mounting

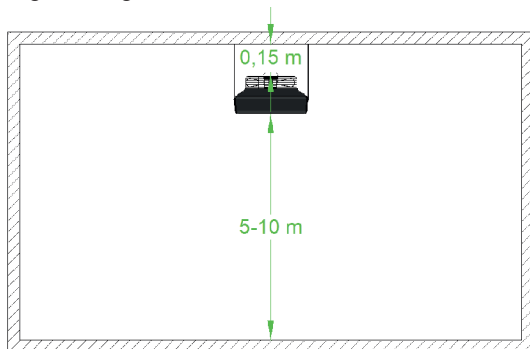

In case of higher heat demand, more units can be installed in the room. In order to ensure proper air flow, it is necessary to maintain the recommended distances between the heaters, as shown in the following figure.

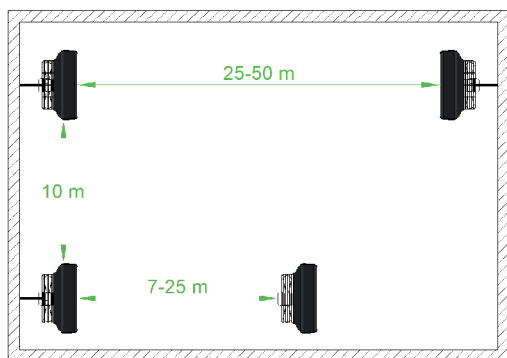

3.2. ROTATING MOUNTING BRACKET

The Reventon Group HC series devices can be assembled using a rotating mounting bracket. It enables the heaters installation on the wall or ceiling, depending on the required optimal direction of airflow.

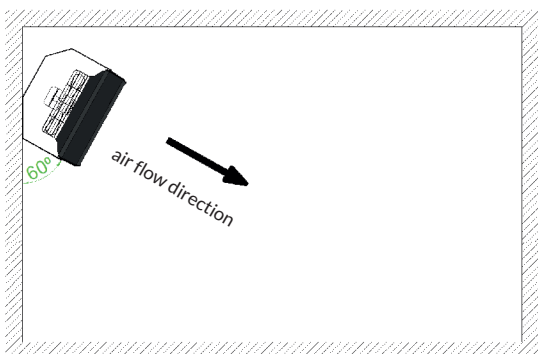

4. INSTALLATION INSTRUCTIONS

4.1. CONNECTION OF THE DEVICE TO THE HYDAULIC SYSTEM

-the wires should be connected as indicated on the heater (supply from below, return from above)

- while plugging the device to the water installation do remember to hold its stub pipes by pipes spanner

Not keeping to the recommendation may cause the damages of the heating coil.

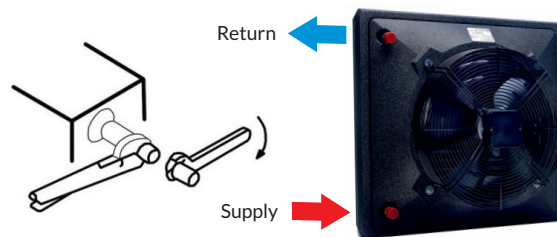

- it is recommended to use filter on the hydraulic supply of the heater

- it is recommended to use the following valves:
• vent valve in the highest place on the hydraulic installation
• cut off valve on the supply and return of the device

- installation has to be secured against excessive increase of pressure

- it is recommended to check the leak tightness of the hydraulic system before plugging the electric supply

4.2. CONNECTION OF THE DEVICE TO THE ELECTRICAL SYSTEM

- all works concerning electrical installation should be made by the qualified personnel (who possess required authorizations to install electrical equipment), based on wiring schematic diagrams (see 7)

- the electrical installation of the building shall have a residual current device

- it is recommended to check the electric installation and controls before the first start

5. PRECAUTIONS & WARNINGS

The precautions mentioned below must be strictly followed during operation of the device:

- all works concerning electrical installation (disassembly, repair etc.) should be made by the qualified staff, who possess the qualifications due to the domestic and local norms, regarding electrical installations

- before service or exchange of the device it is obligatory to cut off the current supply

- do not limit or cover the inlet and outlet of the device

- do not install, service the device with wet hands or barefoot

- the device should be kept out of reach of children and animals

- the device does not consist of the anti-frost protection. The temperature in the room, where device is installed, should not go below 0°C. If such situation could take place empty the device out of water

- after the turn off, the elements of device may be warm

- after operating time of the device, please utilize it concerning the local norms and regulations

- it is recommended to clean the device periodically (at least twice a year):
• heating coil blow through by compressed air
• fan casing and blades clean form the dirt

- if the device is not used for a longer time disconnect the voltage supply

- the device is transported with the closed air stators. It is essential to open them in at least for 30% before first start

- opening the air stators must be done by two hands in parallel (for standard version)



- opening the air stators of diffuser 360° must be done by two hands to the outside (for version with 360° diffuser)

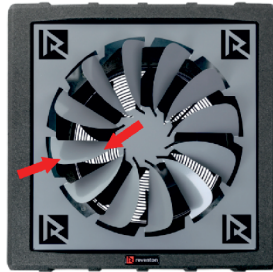

6. CONTROLS

Usage of automatic control dedicated to the air water heaters of Reventon Group gives great possibilities of adjusting the efficiency of the heater in different, depending on needs, degree of automation of its operation. We also offer additional controls:

Programmable controller HMI

Controller is used to regulate devices equipped with 3-stage fans. It controls them according to set program (required air temperature). There is also opportunity to connect the external air temperature sensor (in the set). The controller automatically controls the actuator of two-way valve. It has MODBUS communication too.



Voltage/ Frequency: 230 V AC / 50 - 60 Hz
 Maximum current: 5 A
 Operating temperature range: 0 - 45°C
 Regulation range: 5°C - 35°C
 Regulation accuracy: ± 0,5°C
 External temperature sensor: NTC 10K
 Communication: RS485
 Dimensions: 86 x 86 x 13,3 mm

3-stage speed controller with thermostat HC-3S

Controller is used to regulate devices equipped with 3-stage fans. It has a 3-stage speed control and built-in thermostat switches the device of automatically when the preset temperature is reached. In addition, the unit controls the operation of the actuators installed on the control valve.



Voltage/ Frequency: 230 V AC / 50 - 60 Hz
 Maximum current output: 3 A
 Temperature range: 10°C - 30°C
 Operating mode: continuous or thermostatic
 Control accuracy: < 1°C
 Dimensions: 130 x 85 x 40 mm
 Weight: 210 g
 Degree of casing's protection: IP 30

Fanspeed controller HC

Designed to change the single-phase fan's speed voltage controlled in industrial supply and heating systems. It is available in several versions. The selection of the appropriate model depends on the number of the devices that have to be connected to the to one regulator - the total intensity of the connected devices cannot exceed the maximum current flow of the regulator.



5 control levels: 80-105-135-170-230 V
 Voltage/ Frequency: 230 V AC / 50 - 60 Hz
 Maximum current output (depending on model):
 3 A*, 5 A, 7 A lub 14 A
 Protection: thermal switch
 Dimensions: 126 x 176 x 56 mm
 Weight (depending on model):
 1,3 kg, 3,8 kg, 6,4 kg lub 10,2 kg
 Degree of protection: IP 54

* regulation for 3 A regulator: 115-135-155-180-230 V

Two-way valve with actuator 3/4" (installation on the return from exchanger)

The two-way valve with actuator is used to automatically regulate the flow of the heating medium.



Voltage/ Frequency: 230 V AC / 50 - 60 Hz
 Total current: < 0,25 A
 Maximum operating temperature: 60°C
 Closing time: 5 - 6 min
 Adjustment stroke: 3,6 mm
 Degree of protection: IP 40

Relay Module RM-16A

Relay module RM-16A opens and closes the circuit to affect the work of other devices. It can be used to connect a receiver with higher power than the relay in the controller allows. Maximum rated current is 16A.



Power supply/ Frequency : 230 V AC / 50 - 60 Hz
 Maximum rated current: 16 A
 Input: NO/COM
 Input: SL Connection of a regulator with the voltage relay 230 V
 Dimension: 47 x 47 x 20 mm

Manual thermostat HC

Controls operation of the heater. Switches the unit off automatically when the set temperature is reached.



Power supply/ Frequency: 230 V AC / 50 - 60 Hz
 Maximum rated current: 3 A
 Operating temperature: 0 - 40°C
 Temperature control range: 10 - 30°C
 Control accuracy: < 1°C

COOPERATION OF CONTROLLERS WITH EQUIPMENT

Model	HC3S	HMI	HC 3A	HC 5A	HC 7A	HC 14 A	RM- 16A
HC20-3S	3	5	3	5	8	16	19
HC30-3S	3	5	3	5	8	16	19
HC35-3S	3	5	3	5	8	16	19
HC45-3S	3	5	3	5	8	16	19
HC50-3S	2	4	2	4	6	12	14
HC70-3S	2	4	2	4	6	12	14

7. CONNECTION SCHEMES

LEGEND:

1. Power
2. Main switch, overcurrent circuit breaker *
3. Air water heater Reventon HC
4. 3-stage speed controllers with thermostat
- A-work in continuous mode
- B-operation in thermostatic mode
5. Two-way valve with actuator HC 3/4 "
6. Fan speed controller HC
7. Manual thermostat HC
8. Programmable controller HMI
9. Relay module RM-16A
10. External temperature sensor

* main switch and safety fuses are not included in the set

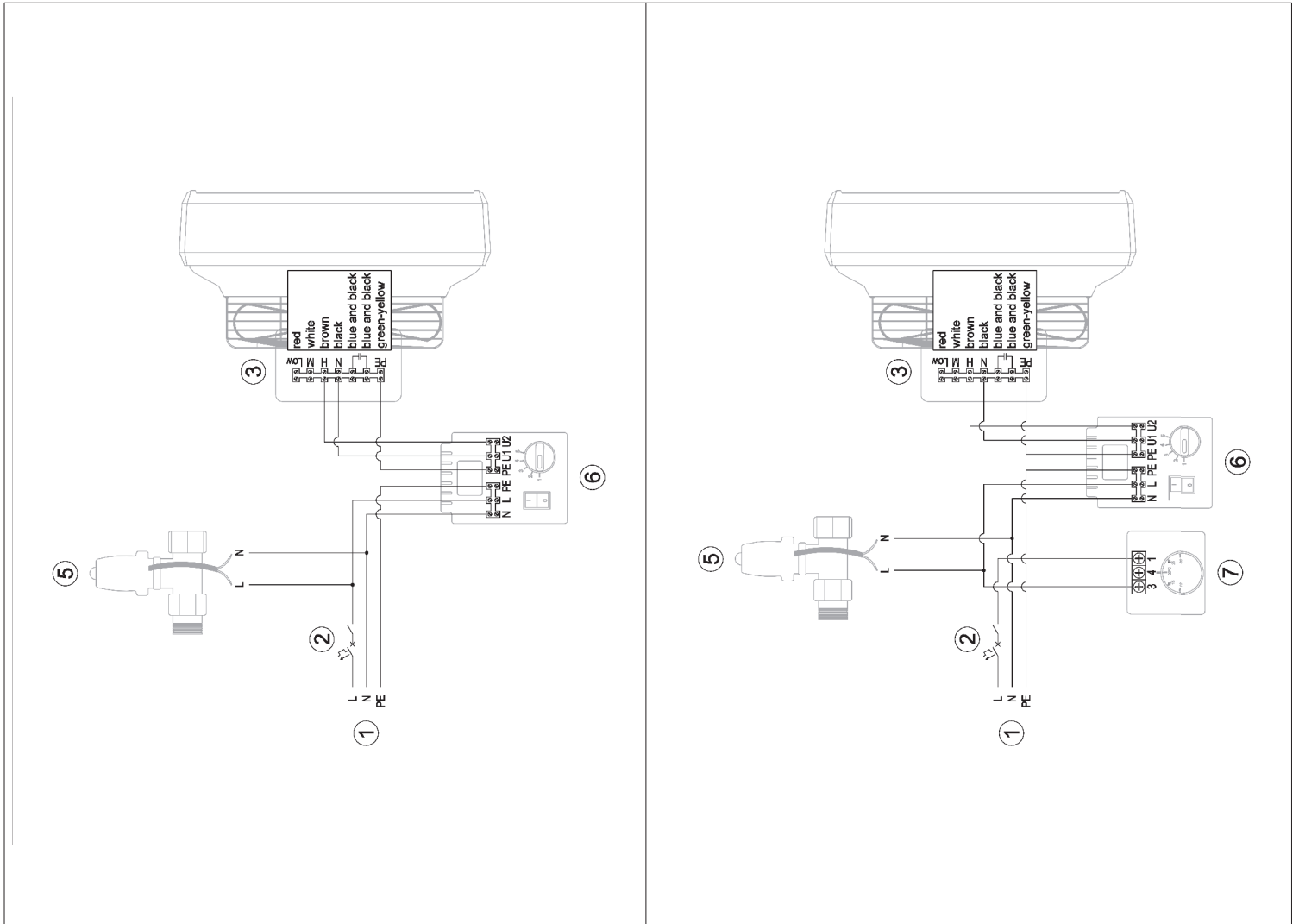

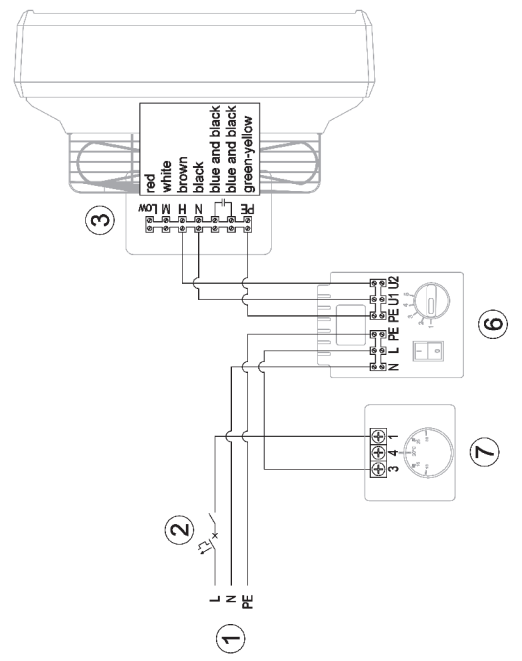
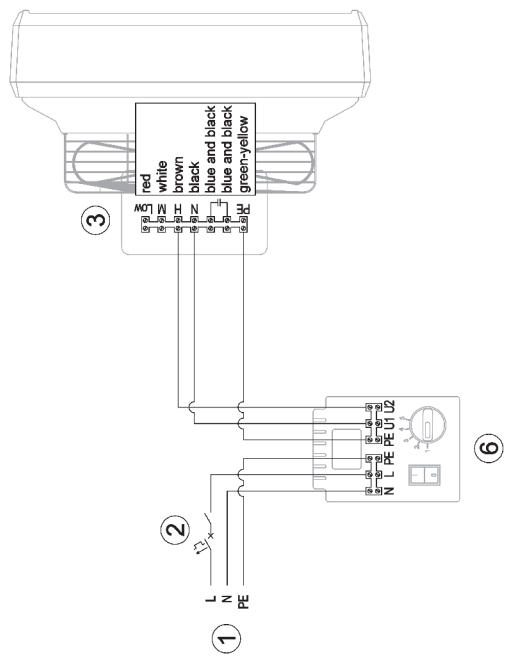

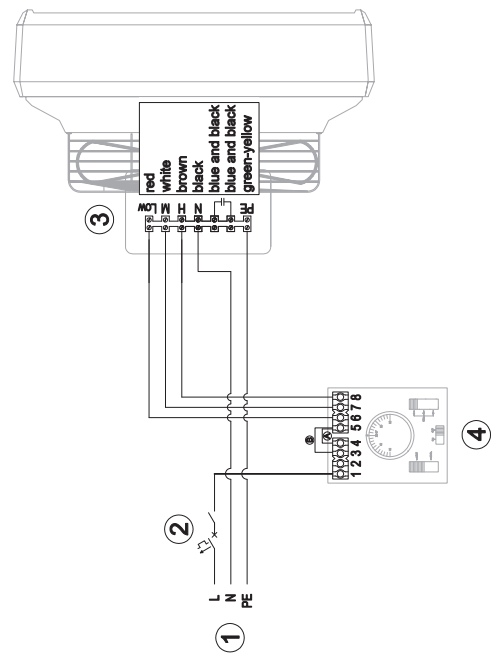
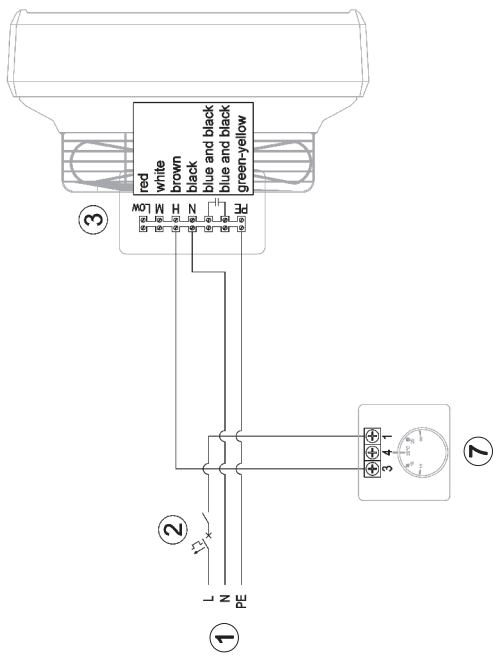
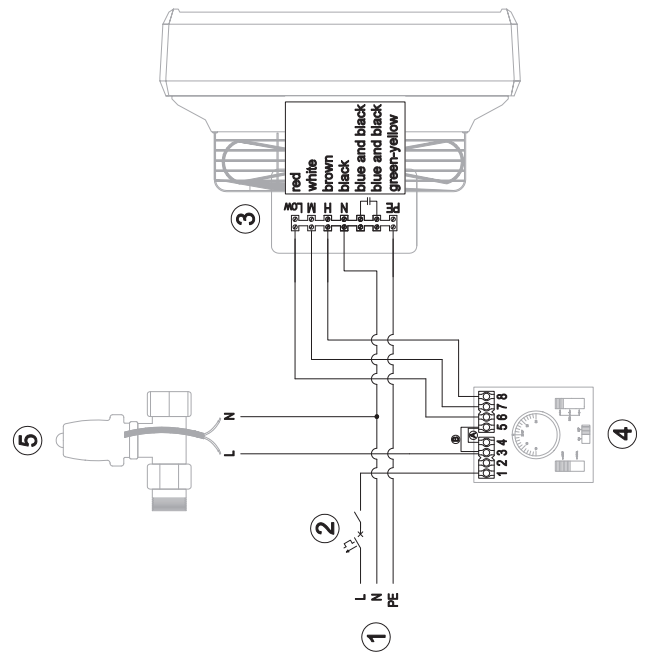
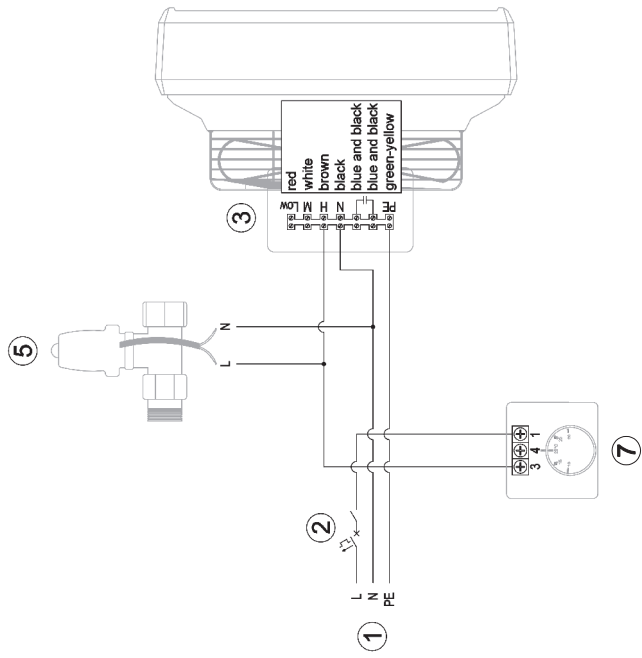

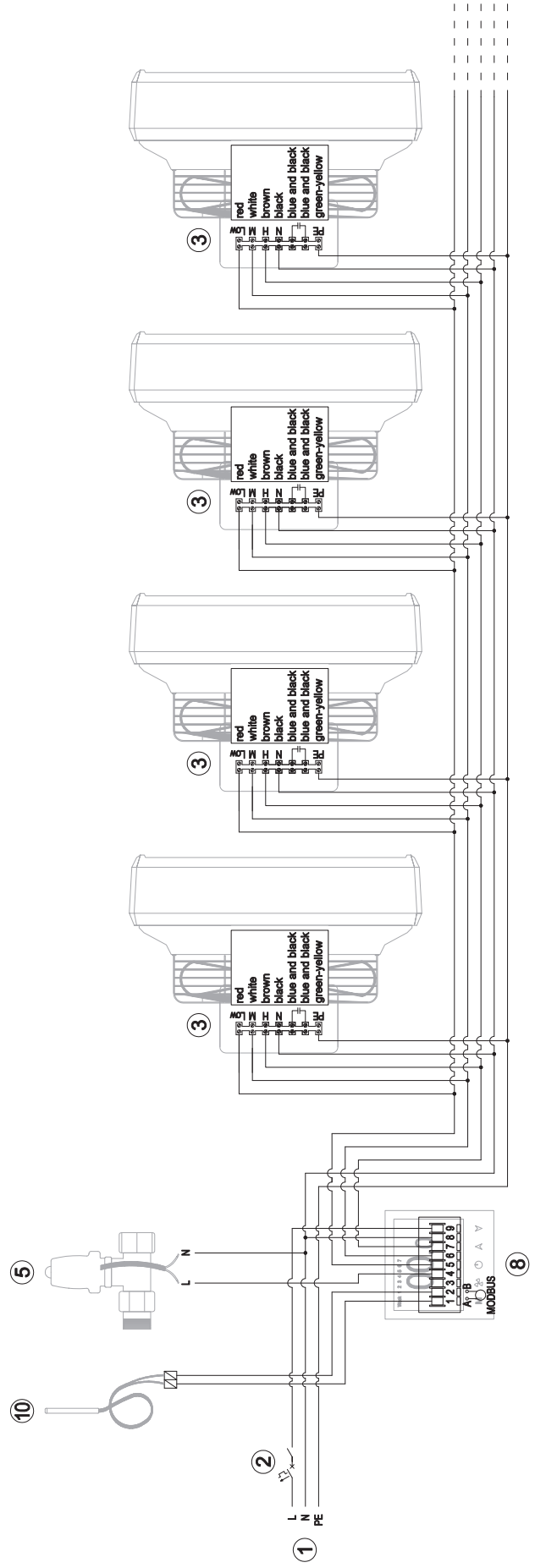
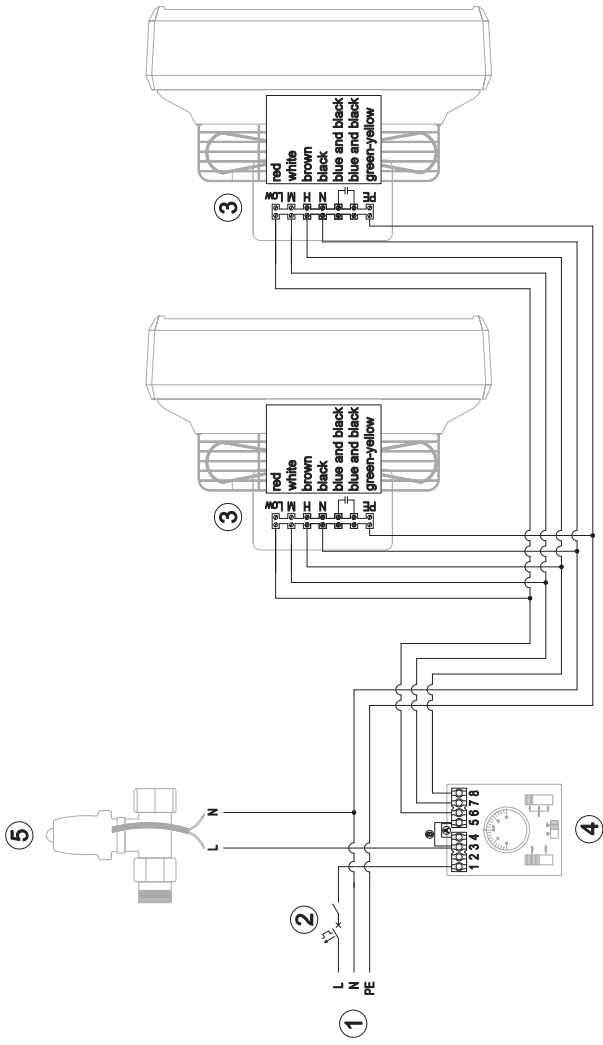

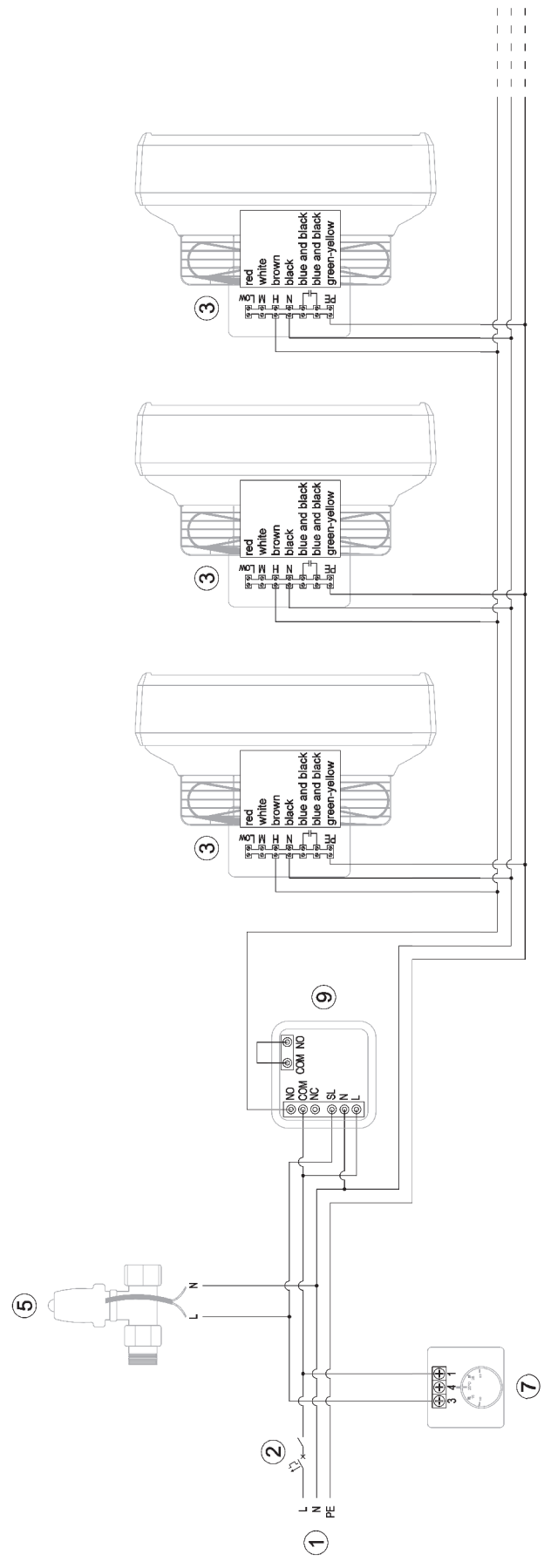
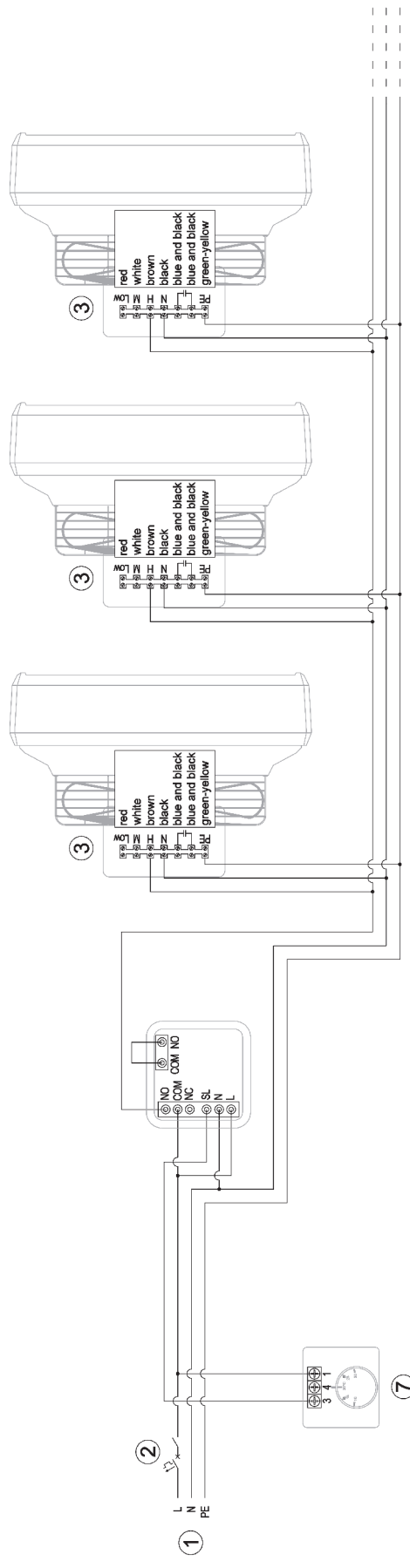

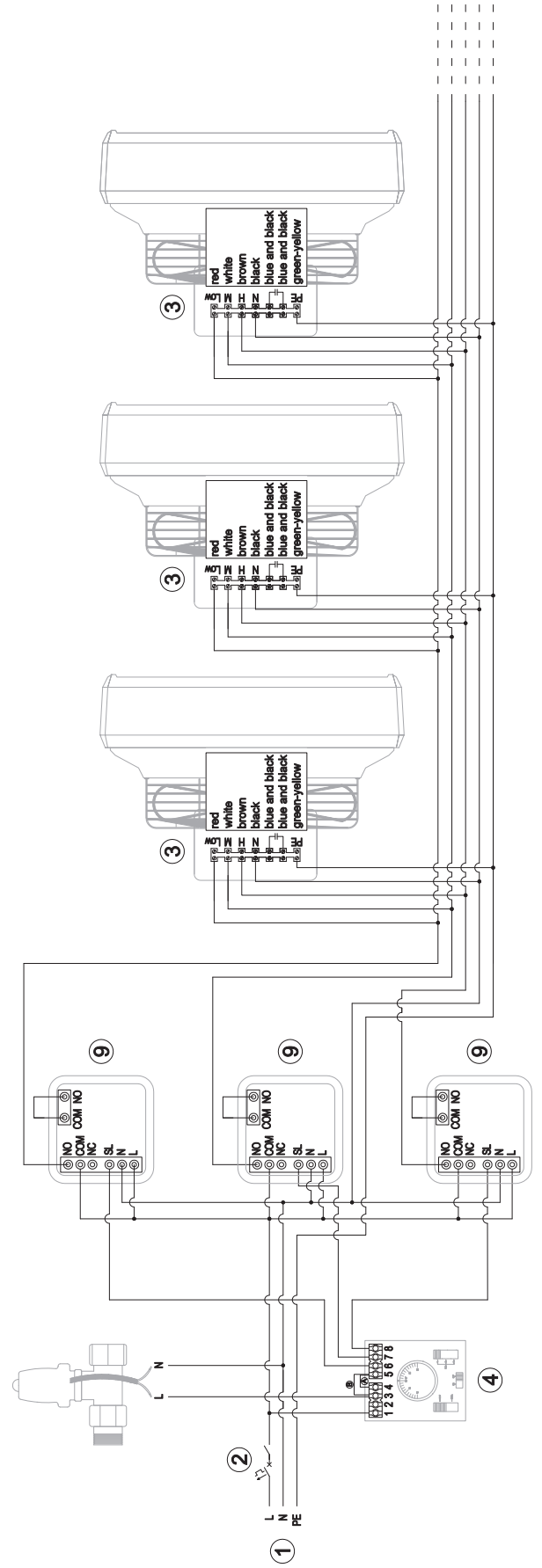
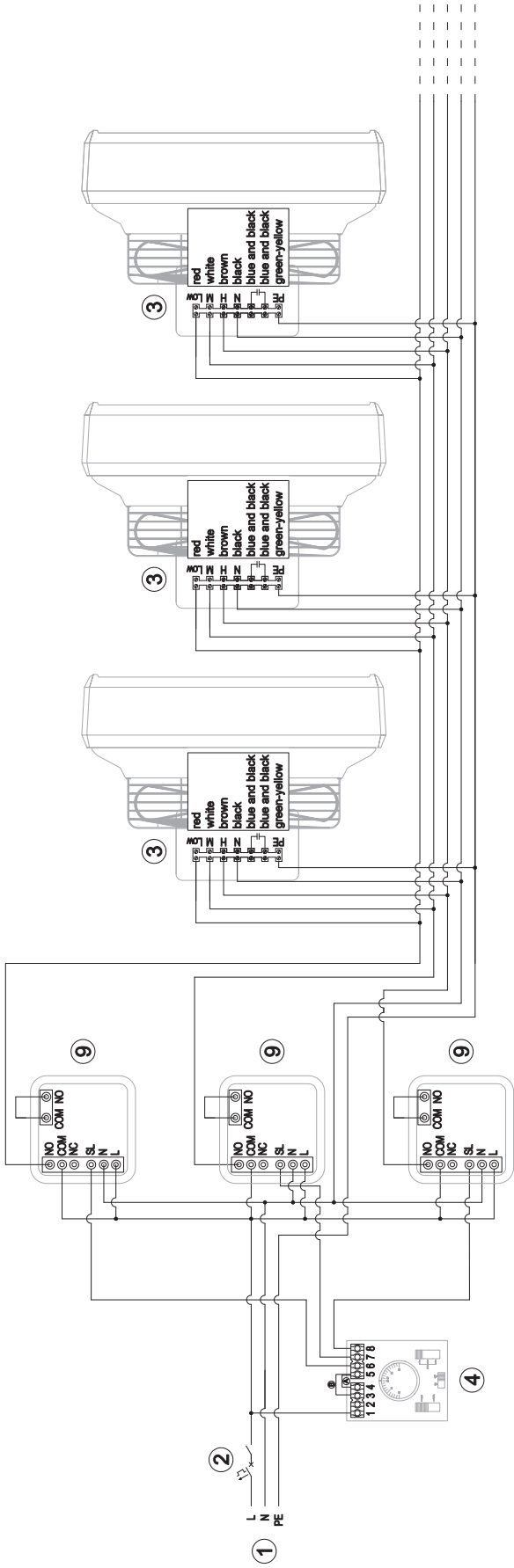

8. TERMS OF WARRANTY

I.Reventon Group Sp. z o.o. [Ltd.] 3B Montazowa Street , 43-300 Bielsko-Biała,Poland, is the producer of the Reventon Group brand. The warranty concerns the following devices and it is valid for 2 (two) years:

- air water heater HC 20-3S
- air water heater HC 30-3S
- air water heater HC 35-3S
- air water heater HC 45-3S
- air water heater HC 50-3S
- air water heater HC 70-3S

II. Warranty is valid in the European Union.

III.The terms of warranty are valid from purchasing the device (the date issuing a document confirming the purchase of the device) but not further than 30 (thirty) months from leaving the producer's warehouse.

IV.The defects revealed during the warranty period will be removed free of charge in 14 working days. The service will be done by the installation company due to the terms of the warranty card. The spare parts will be supplied by the Reventon Group Sp.z.o.o.during the warranty period.

V. In the exceptional cases, the manufacturer reserves the right to extend the time limit for examination of warranty, especially if the defect is not permanent and its determination requires a longer period of time. Any such extension must be notified by the manufacturer before the end of the 14th day (working).

VI. Warranty does not cover the parts of the device subject to normal maintenance and the cases as below:

a) mechanical damage of the product

b) defects and damages through:

- improper storage or transportation
- improper use or maintenance not in accordance with the instructions
- using the device in the improper conditions (too high humidity, too high or too low temperature, impact of the surrounding, sun etc.)
- modified equipment that has been modified or repaired without written agreement of the producer
- connecting additional equipment, which is not recommended by the producer or inconsistent with the technical documentation
- improper power supply

c) elements which wear and tear such as discolor or using

VII. Any changes in the Warranty Terms, improper use of the product (careless handling, exposure to liquids, moisture, corrosion), as well as traces of self-repairing (except for the Reventon Group manufacturer's service), alterations or attempts to make structural changes to the product, (revealed during the performance of warranty service), makes warranty not valid.

VIII. To obtain the service it is needed to send to the producer warranty card with the signature, document confirming the purchase, (copy of the invoice) and correctly filled the warranty form.

IX. Not following to any of warranty regulations makes the warranty not valid.

X. All correspondence, returns, complains should be send to the following address: Reventon Group Sp. z o.o. 3B Montazowa Street, 43-300 Bielsko-Biała, Poland or e-mail: serwis@reventongroup.eu

The producer reserves the rights to make changes to the technical documentation without previous notice.

Warranty card

Factory number of the device:	Address and place of assembly:
Stamp and signature of the installation company:	

Warranty form

The company reporting the complaint:	Date of assembly:	Address and place of assembly the device:
The company installing the device:	Date and circumstances of noticing the defect:	
	Factory number of the device:	Date of declaration the complaint:
Description of the defect:		
Contact Name and Surname, telephone number/ e-mail address:		

Service card

Date of declaration the complaint:	Description of the repair:	Service stamp:
Date of repair:		



reventon
INDUSTRIAL SOLUTIONS

Reventon Group [Ltd.] 3B Montazowa Street, 43-300 Bielsko-Biała, Poland, www.reventongroup.eu